

Die Changes

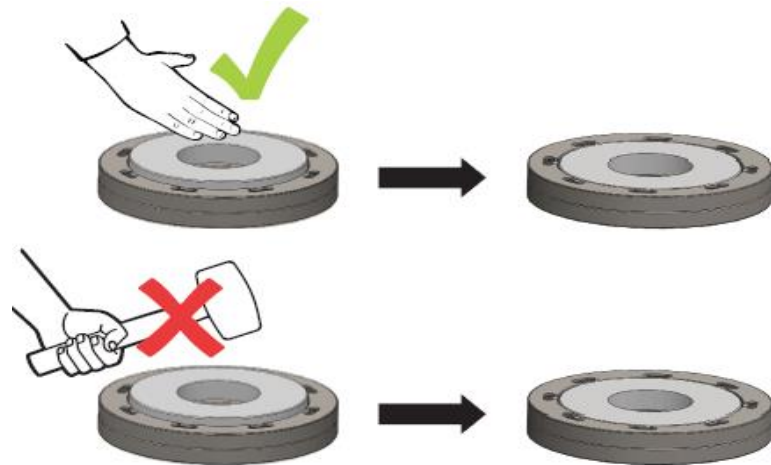

Spring and Pin Replacement

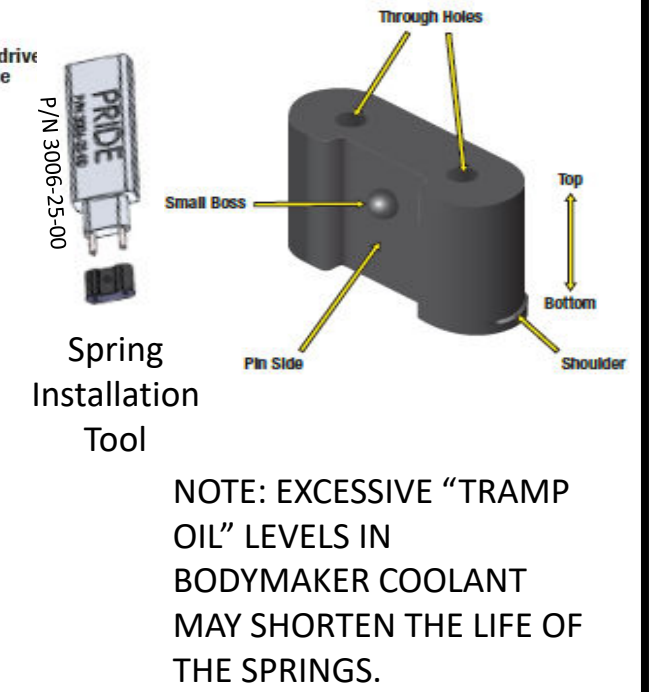
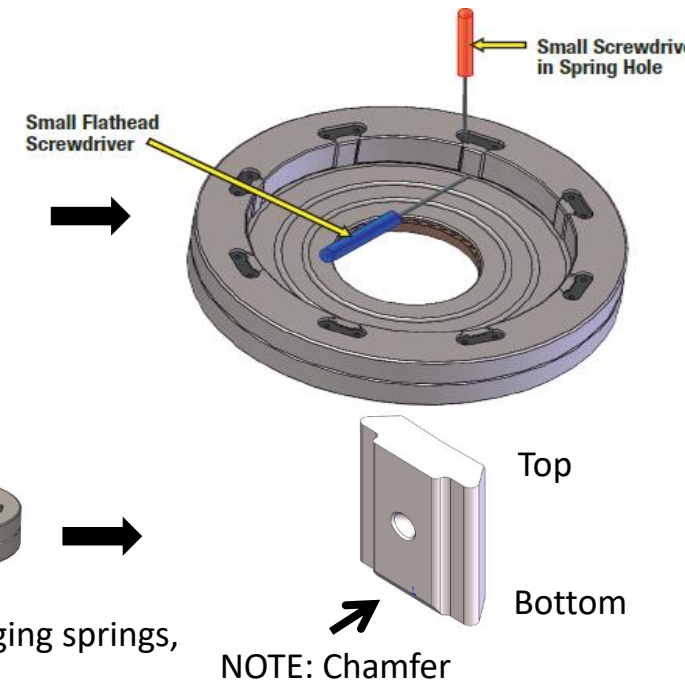
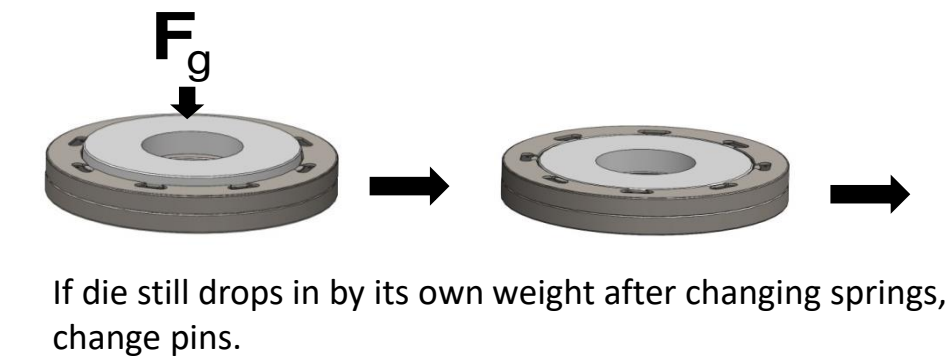
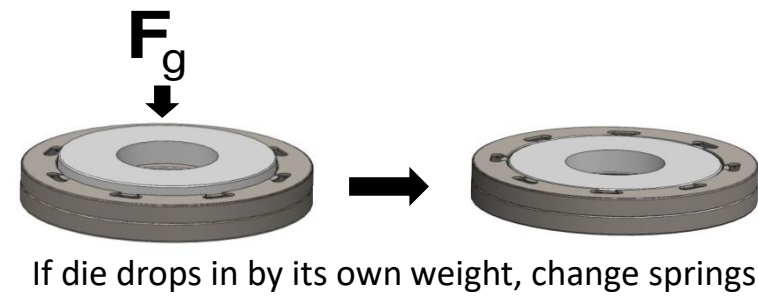

Check for Die Clearance

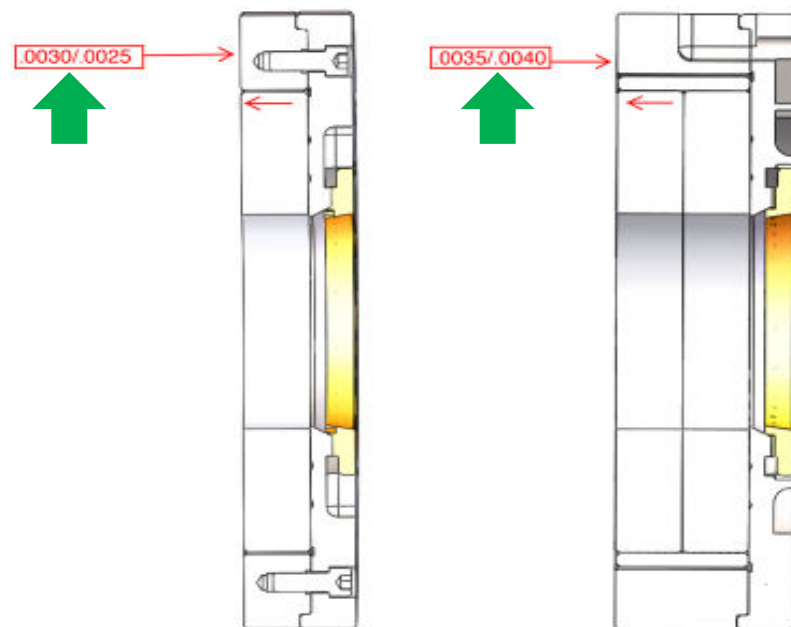

Check Concentricity to OD

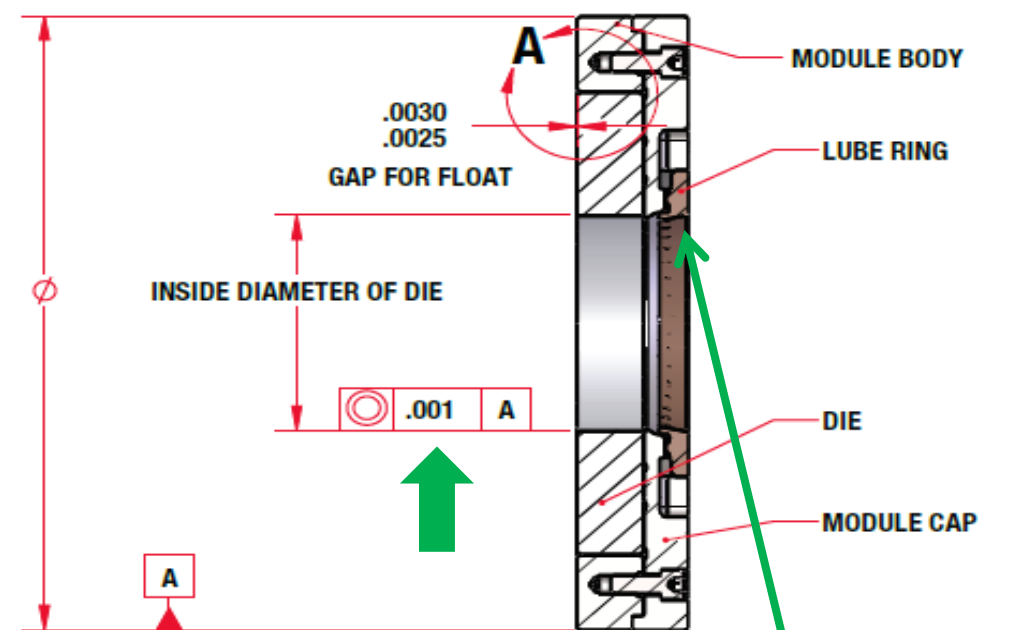

Check Lube Rings

Check lube ring openings to make sure they are not obstructed or damaged.

Check Squareness

